

Cameron

First Ram-Type BOP

An ASME Historic Mechanical
Engineering Landmark

July 14, 2003

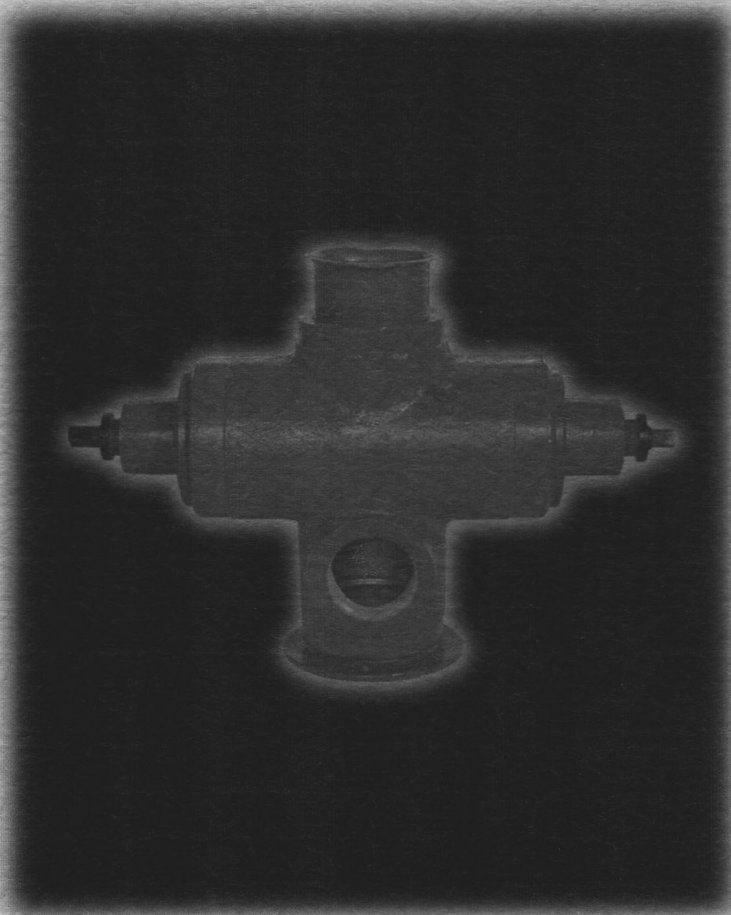

ASME International

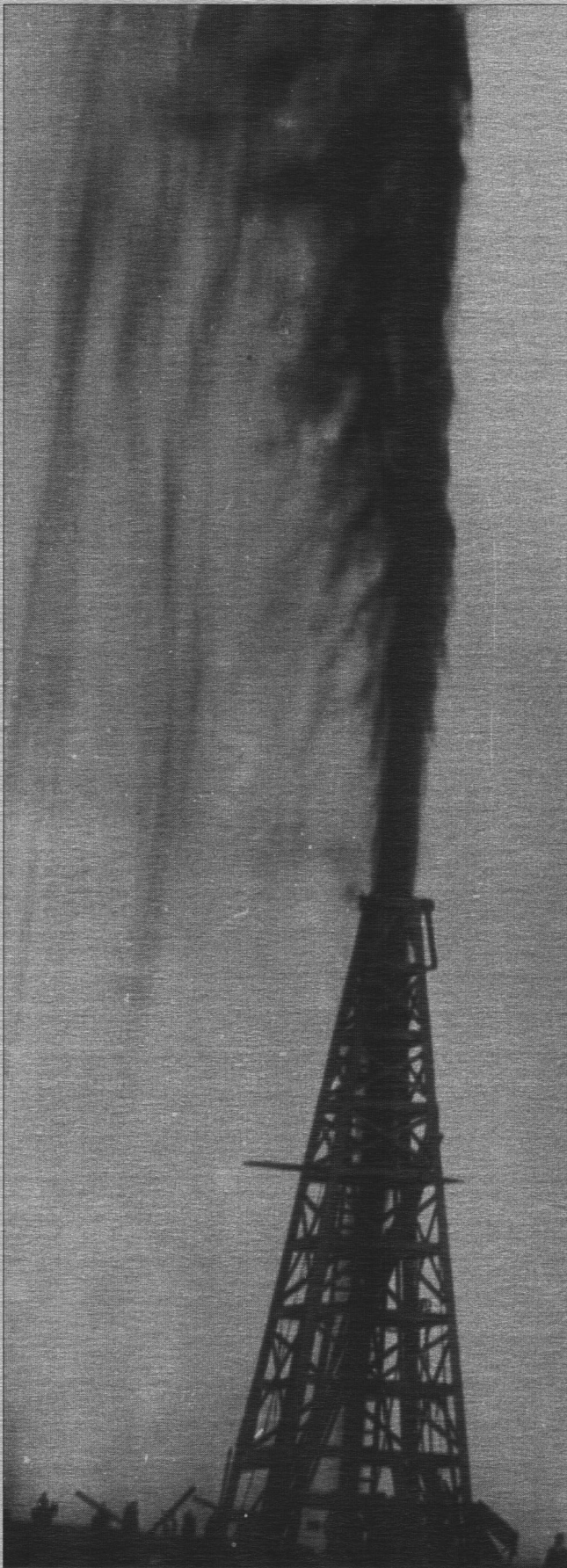

The Lucas gusher spews oil and drill pipe out of the open hole



The Lucas gusher was a spectacular sight and drew quite a crowd.

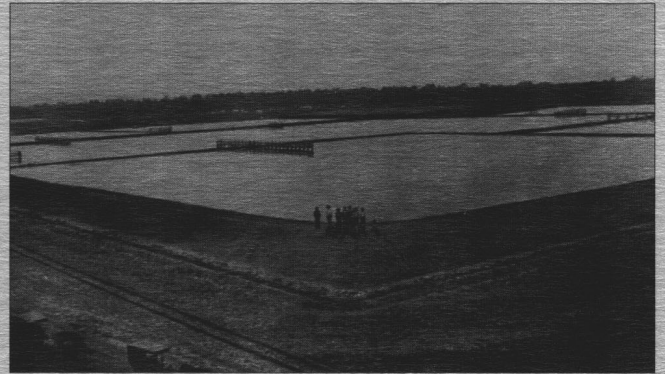

Earthen dams contained the oil in the Spindletop oilfield



Spindletop oilfield workers became soaked with oil as the well blew



One fire often led to other fires in the early oilfields like Spindletop

The Early Oilfields - Spectacular and Dangerous

The early oilfields were dangerous places . When oil was struck, the oilmen would let the oil and gas blow out of the well. Then they would wait until the pressure dropped far enough so that they could manually put pipe into the ground to redirect the flow. These so-called "gushers" were spectacular, but they were also deadly and wasteful. Men were killed and many oilfields were destroyed. In April 1861, a blowout in West Pennsylvania started a fire that killed more than a dozen workers.

Probably the best known "gusher" or "blowout" occurred in the Spindletop oilfield near Beaumont, Texas. On January 10, 1901, a three-man crew was drilling a well for Captain A. F. Lucas. Then 6" casing had been set at 880 feet and the well had been deepened to 1020 feet. The crew was making a trip for a new bit with 700 feet of drill pipe in the hole when the underground pressure caused the well to "kick". After several hard kicks, the well pressure blew the 4" drill pipe out of the hole and in a short time, a 6" stream of oil and gas was gushing from the well, spraying more than 100 feet into the air. The Beaumont newspaper described it as " An Oil Geyser - Remarkable Phenomenon South of Beaumont - Gas Blows Pipe from Well and a Flow of Oil Equalled Nowhere Else on Earth."

The crew on the Lucas gusher had never seen or heard of a blowout or a blowout preventer. Following the accepted practice of the time, there was nothing on top of the casing to shut off an unexpected flow from the well. When the mud and oil started flowing out of the hole, they did the only thing they could do — run and get out of the way.

Oil gushed from the wide open Lucas well for nine days before a valve could be attached and closed to stop the flow. Earthen dikes were built around the gusher to contain the crude oil and about 500,000 barrels of oil accumulated. But, several days later, it was all lost during a fire.

If the fledgling oil industry was to grow and prosper, a means of preventing such tragedies had to be developed.



Early wells were drilled with nothing installed above the drill pipe to control pressure.

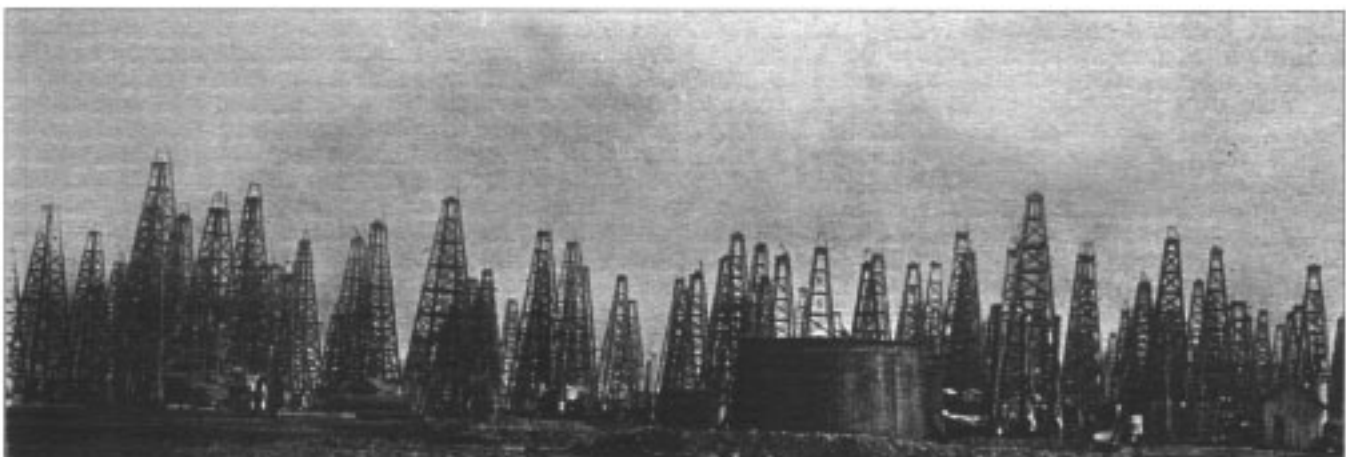

A panoramic view of the Spindletop Oilfield taken in 1902 clearly shows the proximity of the wells and the danger of one well fire leading to another.

Controlling the Pressure - The Cameron MO BOP

The perils of the early oilfields did not go unnoticed. As wells got deeper, formation pressures increased and blowouts were becoming more and more frequent. Several inventors tried to come up with ways to stop the blowouts. These "blowout preventers" or BOPs, were designed to be installed on the wellhead to stop the disastrous gushers. None of the designs proved successful.

Oilman Jim Abercrombie, nearly the victim of a disastrous blowout himself, became frustrated and enlisted the aid of renowned machinist Harry Cameron to tackle the problem.



The Cameron MO BOP

Abercrombie knew that there must be a way to make a BOP that would really work. Using his creative genius in conjunction with his training in engineering and hydraulics, he came up with the idea for a ram-type preventer with the faces of rams (simple hydrostatic pistons) closing on the drill stem to form a seal against the well pressure. Abercrombie took his idea to Cameron and the two worked out the details of the design drawing in the dirt floor of Cameron's machine shop in Houston.

Abercrombie and Cameron filed a patent application for the MO BOP on April 14, 1922. The simple, straightforward design of the MO was summed up in words from the application, "Another object is to provide a blowout preventer of the kind described, which will be composed to a minimum number of parts of simple and rugged construction." The application was acknowledged and the basic patent was granted January 12, 1926 - U.S. patent number 1,569,247.



"With a roar like a hundred express trains racing across the countryside, the well blew out, spewing oil in all directions. The derrick simply evaporated. Casings wilted like lettuce out of water, as heavy machinery writhed and twisted into grotesque shapes in the blazing inferno."

An account of the event that almost cost Jim Abercrombie his life, and led directly to his invention of the first blowout preventer.

Tests and improvements on the basic design extended over two years and in January of 1924, Abercrombie and Cameron began to market the MO. In the meantime it was discovered that the original MO was fundamentally sound, but allowed some fluid to escape between the ram faces and drill stem as pressure increased. Abercrombie and Cameron resolved this by adding specially fabricated packing between the ram faces and the stem. Extensive testing showed that the leakage was virtually eliminated by the design revision which was granted patent number 1,498,610 as an improvement on the original MO concept.

Several factors made Abercrombie and Cameron successful where others had failed. Both Abercrombie and Cameron were experienced oilmen and Cameron understood just how rugged oilfield "iron" needed to be. The MO BOP had a metal body with a vertical bore that was installed on top of the well casing. Two cylindrical-shaped bores intersected the vertical bore at right angles. The MO body and screws were made of steel, while the rams and heads were made of cast iron. The rams were closed manually by means of threaded stems attached to long extension socket

wrenches. When the wrenches, which were extended under the derrick floor to a safe distance from the well, were turned, the rams closed against the drill pipe. The BOPs were tested in the shop to hold 2000 psi pressure.

But it was the rams that really set the MO apart from other designs. The packing on the MO rams incorporated an ingenious V-shaped notch in one of the faces near a corner. This notch, when placed in the direction of the fluid pressure, opened, forcing the thin lip against the sealing surface. Cameron found that this cross-sectional configuration allowed the MO packing to hold 15 to 100 times as much pressure without allowing seepage than with a regular square cross section. The MO was also the first BOP to hold 3000 psi of pressure, an industry record at the time.

By 1924, Cameron Iron Works was already advertising and selling the MO BOP for 6" and 10" diameter casing. By 1925, the cast iron parts were replaced with steel. With this improvement, Abercrombie and Cameron added 12" and 12-1/2" preventers to their line. By 1925, Cameron's customers included all the major producers in South Texas; some were even shipped to Mexico and Venezuela.

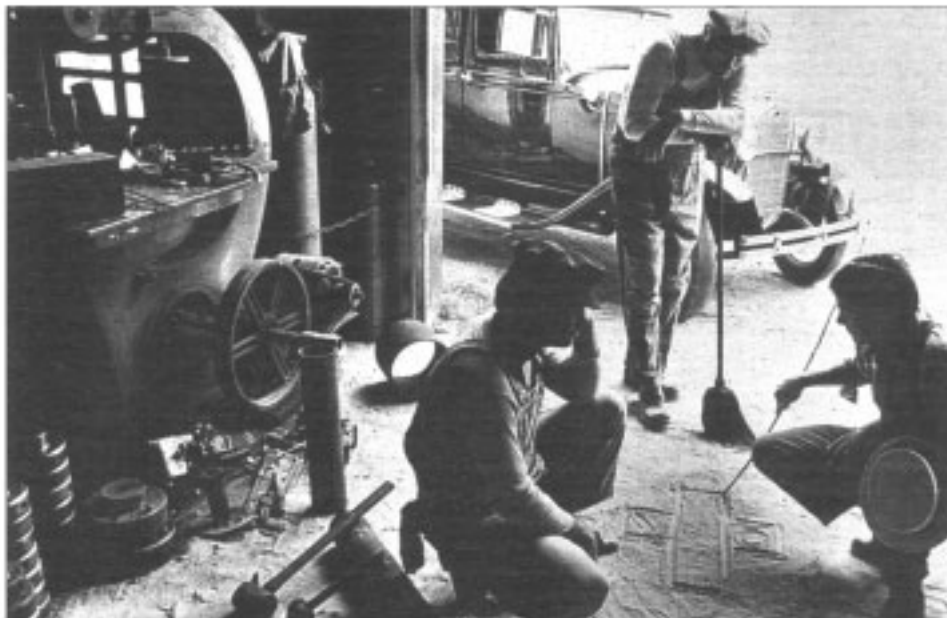

Jim Abercrombie and Harry Cameron sketched the first successful BOP in the dirt floor of a small machine shop on Milby Street in Houston, Texas. Cameron was known as a machinist who could work miracles with metal. Abercrombie was known as a man who had "big ideas" and could motivate others to make those ideas happen.

The Cameron MO BOP - How It Works

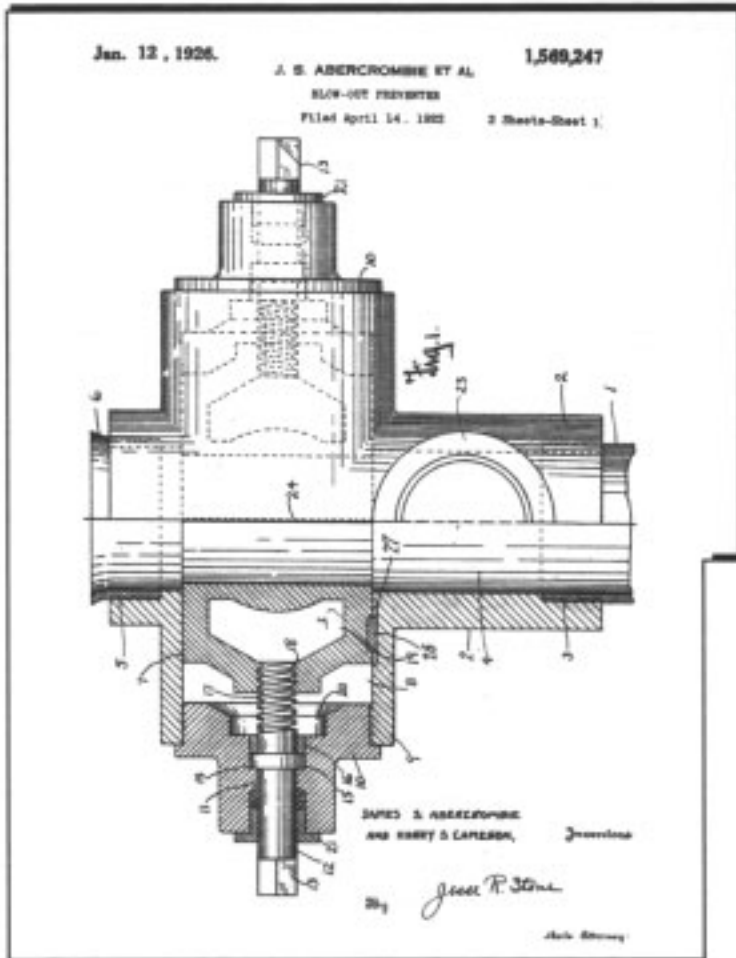

MO BOP Specifications	
OD Casing Size:	8-5/8"
Length of Body:	28"
Length Overall:	49"
Height:	26"
Net Weight Including Wrenches:	1380 lb

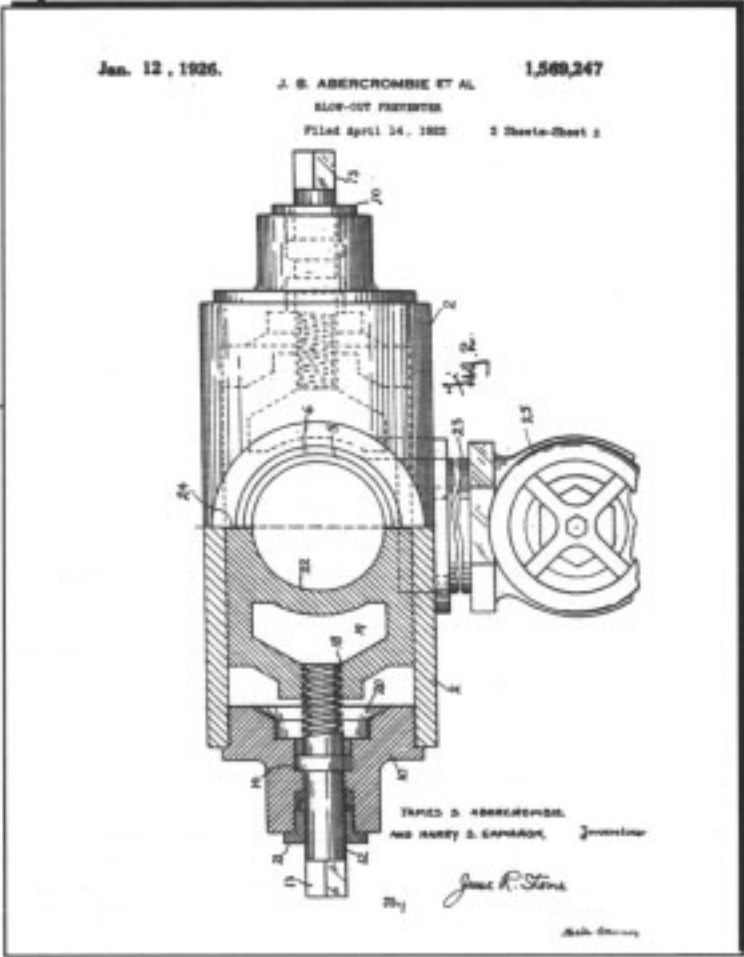

Pages from the original patent application for the MO Blowout Preventer filed by Jim Abercrombie and Harry Cameron April 14, 1922. The patent was granted January 12, 1926 as United States patent number 1,569,247.

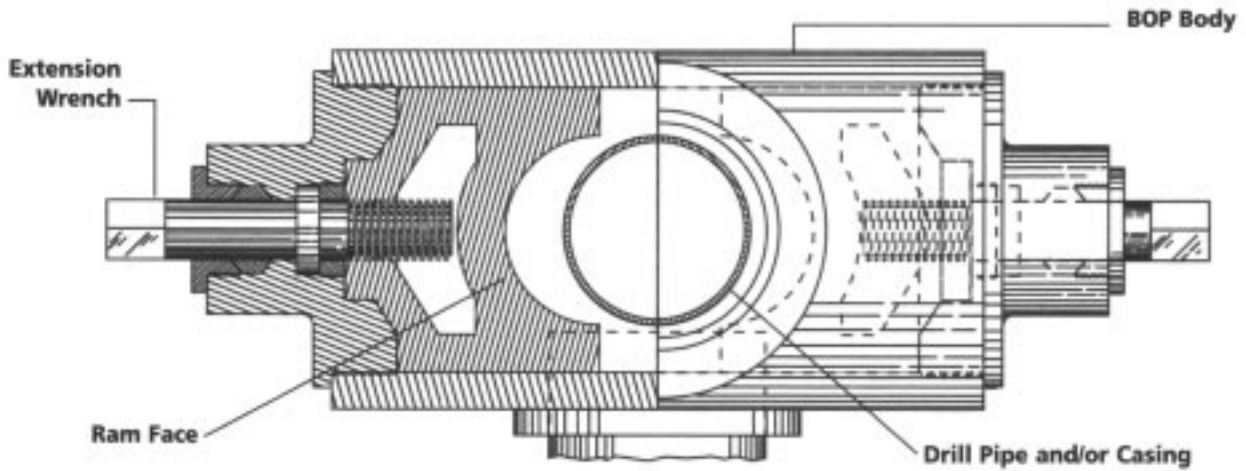

MO BOP in the fully open position. The ram faces are retracted back, away from the pipe in the bore.

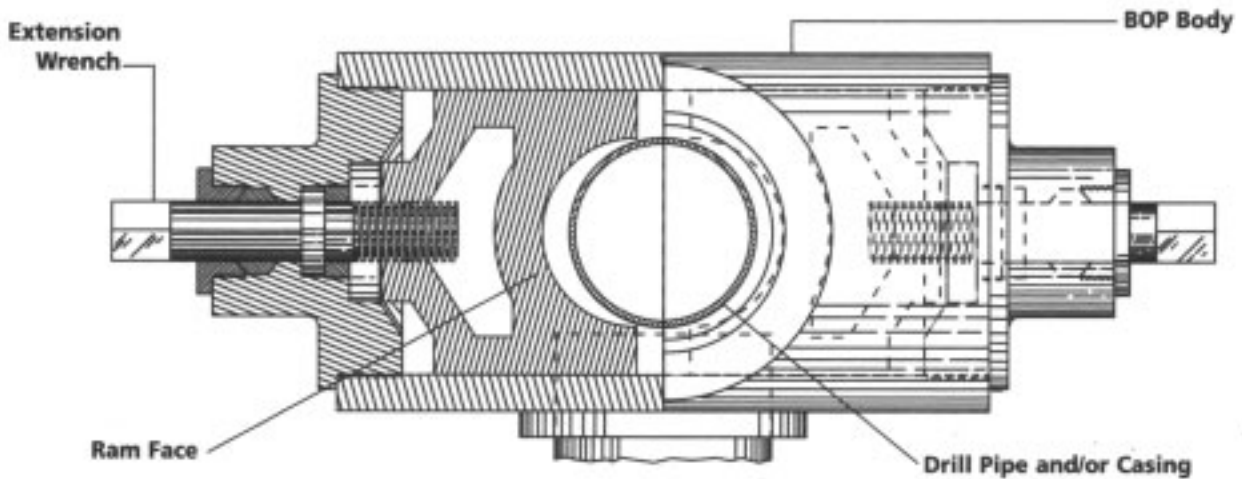

As the socket extension wrenches were turned, the ram faces moved together towards the pipe in the bore.

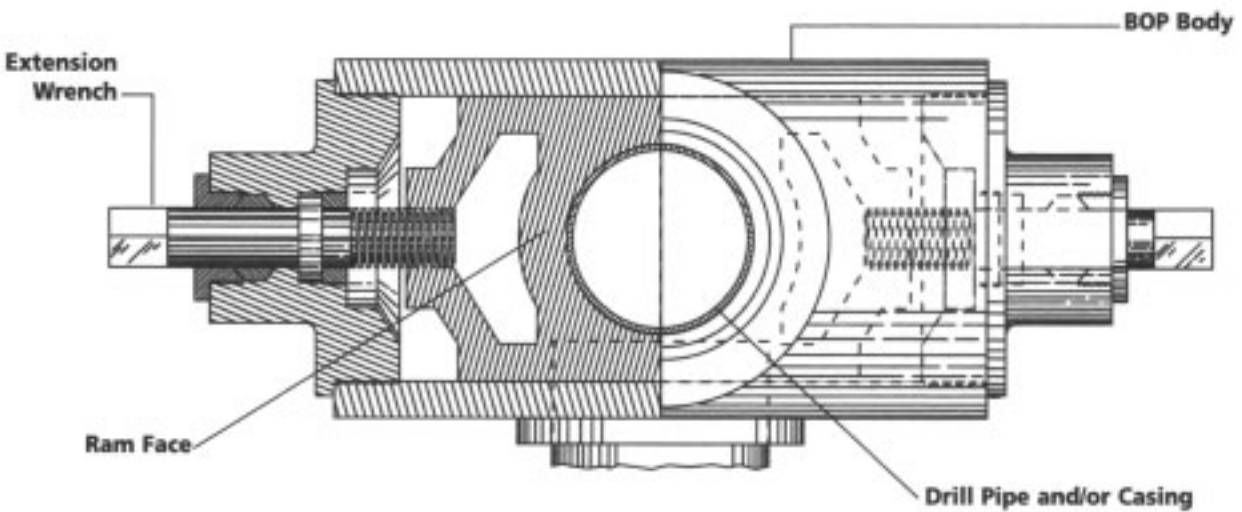

When the socket extension wrenches were fully tightened, the ram faces were moved into direct contact with the pipe in the bore, forming a seal to prevent well bore pressure from escaping.

The Inventors - Harry Cameron and Jim Abercrombie

Harry Cameron was born in Indianapolis, Indiana, on July 9, 1872. He attended high school in Washington D.C., and college in Memphis, Tennessee at Christian Brothers College where he studied architectural and mechanical engineering. Cameron served his apprenticeship at Bierce Hydraulic Compress Company in Little Rock, Arkansas. There, he invented and patented the first hydraulic cotton baler. He then moved on to Dallas, Texas where he worked for a year at Texas Portland Cement Company. Cameron then went with thousands of others into the oil fields, where he established himself as a skilled machinist who could fix equipment, and make any piece needed for the rig floor promptly and properly.

In 1918, Cameron and others formed a new company, the Cameron-Davant Company. The new company machine shops were in Humble, Goose Creek and Houston. The Houston shop was located in as simple corrugated iron building at 711 Milby Street. Harry Cameron bought a house on nearby Rusk Street, where he lived until his death in 1928.



Jim Smither Abercrombie was born in Huntsville, Texas, on July 7, 1891. At the age of 15, his family moved to the Fourth Ward of Houston, where his father started a dairy farm. Abercrombie worked for his father until he was 17. He and a brother then went to look for work in the oil business, to make money to hire extra hands at the dairy.

In 1909, Charles Abercrombie, Jim's cousin, hired him to work as a roustabout for the Goose Creek Production Company, and in 1910 he became a driller. In his early 20s, he worked as a field superintendent for a few wells for Crown Petroleum, and he became the first to use salt water to put out well fires when no fresh water was available. Abercrombie saved his money and bought a used drilling rig in 1918. By 1920, he owned several rigs, so he left Crown Petroleum to work on his own in the oilfields of South Texas and the Gulf Coast.

Abercrombie, or Mr. Jim as he came to be known, soon realized that his equipment was in constant need of repairs. Mr. Jim met Harry Cameron at Goose Creek and brought him plenty of business. Over the years the two men developed a great respect for each other, recognizing each other's talents. Abercrombie said of Cameron, "Harry Cameron was a great machine-tool man. You could give him a piece of iron and he could make just about anything you wanted."

In 1920, Abercrombie and Cameron decided to form a company together that would serve both their interests. They named the company Cameron Iron Works and bought the Milby Street shop and the land from the Cameron-Davant Company for \$17,324.31, and it became Cameron Iron Works, Inc. The company began with seven stockholders holding 250 shares of stock. Abercrombie owned 145, and Cameron held 65 shares. Although

Harry Cameron (left) and Jim Abercrombie (right) were a rather unlikely pair. Cameron was a machinist who could work miracles with metal. Abercrombie was a visionary and a deal-maker, head of his own independent drilling company and constantly in motion from one drill site to the next.

Cameron was the vice president, and Abercrombie the president, Harry continued to work on the shop floor. He was the most skilled and experienced machinist, and it was where he preferred to work.

The invention of the MO BOP in 1922 was just one of the things that put Cameron Iron Works on the map. Within a few years, the Cameron product line expanded to include more than 30 "pieces of iron" including a patented casing cutter and ingenious joints, claims and shoes.



Harry Cameron with some of the "pieces of iron" made at Cameron Iron Works.

The company operated under the name of Cameron Iron Works until 1990 when it was purchased by Cooper Industries. In 1995, Cooper Industries spun-off their petroleum divisions into a new corporation - Cooper Cameron Corporation. The Cameron division of that corporation continues to design and manufacture BOPs.

In today's oil and gas industry, BOPs continue to protect drilling rigs, rig workers and the environment from costly blowouts. Ram-type BOPs are still "The Measure Of Technology" today. Although modern designs look very little like the original MO BOP, the concept of rams closing around the drill pipe is still being employed. Today, ram-type BOPs are available in bore sizes up to 26" and in working pressures up to 15,000 psi. In addition, BOPs have been adapted for use in subsea applications where a typical BOP stack may weigh more than 300 tons and be utilized in 10,000 feet of water.



Harry Cameron and Jim Abercrombie joined together to form Cameron Iron Works in 1920. They called the company Cameron because Abercrombie already had a drilling and minerals company named after him.

The History and Heritage Program of ASME International

The History and Heritage Landmarks Program of ASME International (the American Society of Mechanical Engineers) began in 1971. To implement and achieve its goals, ASME formed a History and Heritage Committee initially composed of mechanical engineers, historians of technology and the curator (now emeritus) of mechanical engineering at the Smithsonian Institution, Washington, D.C. The History and Heritage Committee provides a public service by examining, noting, recording and acknowledging mechanical engineering achievements of particular significance. This committee is part of ASME's Council on Public Affairs and Board on Public Information. For further information, please contact Public Information at ASME International, Three Park Avenue, New York, NY 10016-5990, 1-212-591-7740.

Designation

Since the History and Heritage Program began in 1971, 226 landmarks have been designated as historic mechanical engineering landmarks, heritage collections or heritage sites. Each represents a progressive step in the evolution of mechanical engineering and its significance to society in general. Site designations note an event or development of clear historic importance to mechanical engineers. Collections mark the contributions of a number of objects with special significance to the historical development of mechanical engineering.

The Landmarks Program illuminates our technological heritage and encourages the preservation of the physical remains of historically important works. It provides an annotated roster for engineers, students, educators, historians and travelers. It helps establish persistent reminders of where we have been and where we are going along the divergent paths of discovery.

The 120,000-member ASME International is a worldwide engineering society focused on technical, educational and research issues. ASME conducts one of the world's largest publishing operations, holds some 30 technical conferences and 200 professional development courses each year, and sets many industrial and manufacturing standards.

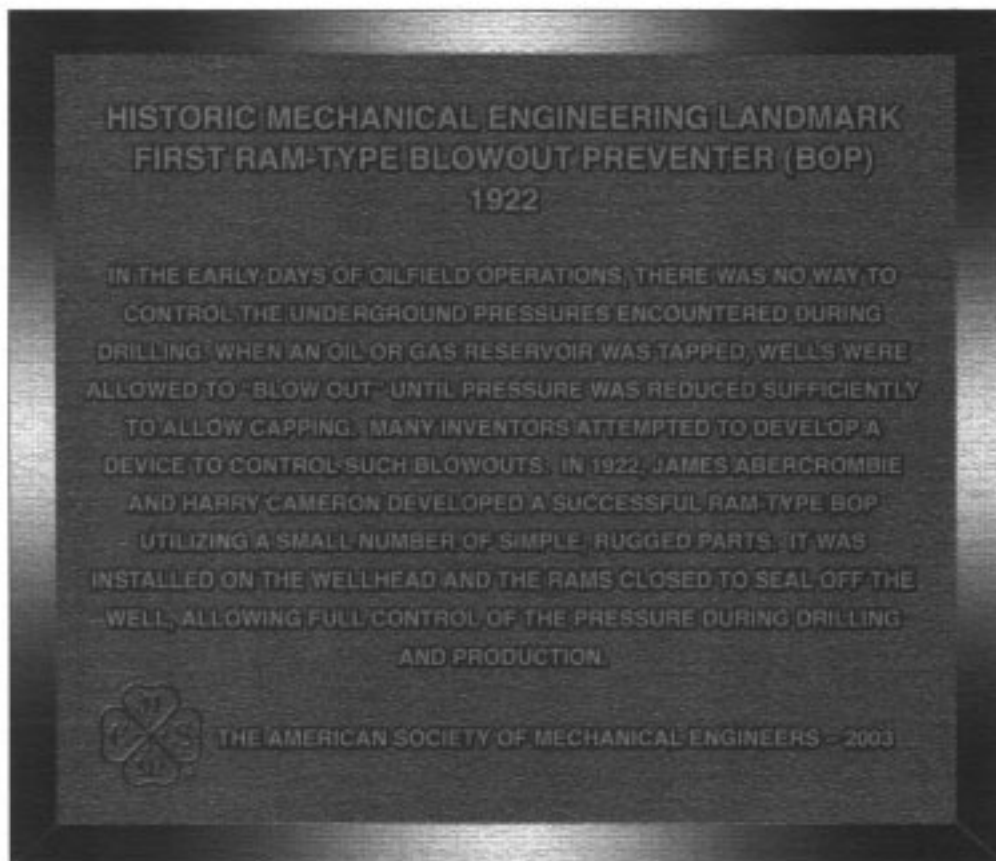

Acknowledgements

The South Texas Section of the American Society of Mechanical Engineers International acknowledges the efforts of all who contributed to the designation of the Cameron Ram Type Blowout Preventer as a ASME Historic Mechanical Engineering Landmark. Particular thanks are extended to Mr. Glenn MacDonald, PE who submitted the nomination. Mr. Sam Collier who provided insight on the unit, Mr. Mike Mikulenska and Ms. Sharon Sloan who provided much of the historical material and information, and members of the Cameron Marketing Communications Department who helped plan and publish this brochure.

ASME International

Reginald I. Vachon, P.E., President

J. Brian Dietz, P.E., Vice President, Region X

Mark W. Powell, P.E., History and Heritage Chair, Region X

Victoria A. Rockwell, Senior Vice President, Public Affairs

Stacey Swisher Harnetty, Vice President, Public Information

Virgil R. Carter, FAIA, Executive Director

Burton Dicht, Director, Southern Field Office

ASME History and Heritage Committee

R. Michael Hunt, P.E., History and Heritage Chair

Robert M. Vogel, Secretary

John K. Brown

William DeFotis

Robert Friedel

Paul J. Torpey, Past President

Herman Viegas, P.E.

Diane Kaylor, Staff Liaison

Wil Haywood, Public Information Coordinator

ASME South Texas Section

Ross L. Kastor, P.E., Chair

Christophe R.I. Sunderman, Vice Chair

Richard S. Boswell, Jr. P.E. History & Heritage Chair

Glenn E. MacDonald, P.E., History & Heritage Vice Chair

Sam E. Collier, Historian Emeritus

Daniel C. Davis Secretary

References

Kleiner, Diana J. "Cameron Iron Works, Houston". The Handbook of Texas Online tsha.utexas.edu.

Nicholson, Patrick J. Mr. Jim - The Biography of James Smither Abercrombie. Houston; Gulf Publishing Company. 1983.

Petroleum Extension Service, Industrial and Business Training Bureau The University of Texas at Austin - Division of Extension, Lessons in Rotary Drilling Unit III Lesson 3 Blowout Prevention Petroleum Extension Service, Industrial and Business Training Bureau. The University of Texas at Austin - Division of Extension, 1974.



CAMERON